



Installation guide for tamper evident Security Seals

For use with the LOGISTICK Logipad, Wedge XL or Wedge International

For best results, please read through all instructions prior to installation.

- 1** Locate Tamper Evident Slot.
The slots are found on the Logipad, Wedge XL and Wedge International on the upper part of the pocket. Refer to the Logipad picture below for the general area of slots.

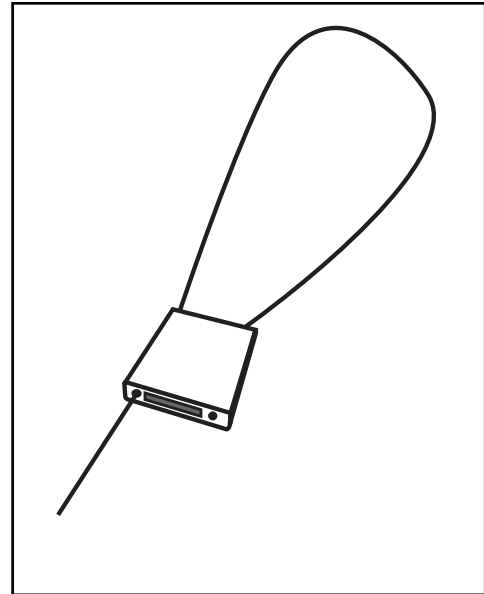
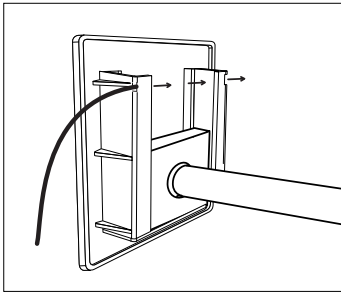

- 2** Pass the seal through both slots. Continue the seal underneath the load lock or 4x4, completing the circle to meet the opposite end with the latch. Fasten or secure tamper evident seal. Caution, once the wire has passed through the body of the seal, it locks in place. Make sure to have it in correct placement.

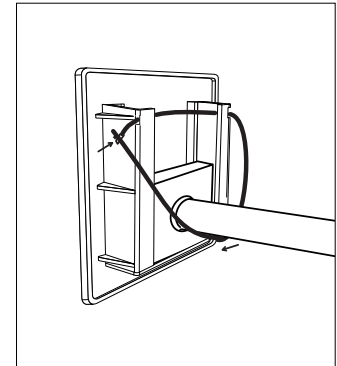

www.logistick.com

19880 State Line Road • South Bend, IN 46637
1.800.758.5840 • 574.271.2565 • FAX 574.271.2574

WARNING: This product is not to be used in connection with the transportation of any "hazardous materials" as defined at 49 CFR § 171.8.

Logistick®, Inc. is a registered trademark. The Logipad is a trademark of Logistick®, Inc.

LOGISTICK®, INC. warrants its product to be free from any defects in material and workmanship. LOGISTICK'S obligation is limited to furnishing, on an exchange basis, replacement parts which may have been found defective upon LOGISTICK inspection. LOGISTICK assumes no shipping responsibility for replacement parts. EXCEPT AS SPECIFICALLY PROVIDED HEREIN, THERE ARE NO OTHER WARRANTIES, EXPRESSED OR IMPLIED, INCLUDING, BUT NOT LIMITED TO, ANY IMPLIED WARRANTY OF MERCHANTABILITY OR FITNESS FOR A PARTICULAR PURPOSE. In addition, under no circumstance will LOGISTICK, INC. be held liable for any damages or claims, including the losses of profit or business interruption, all of which are hereby expressly waived by the purchaser.