

LOGISTICK

Innovators of Freight Securement Systems™

Complete installation guide for the Super Strap™, the one-way solution for securing lightweight, regular- and irregular-shaped loads.

For best results, read before time of installation and follow all directions closely.

- 1 Planning the Location.** The Super Strap must be secured to the wall at least 4 ft. before the end of the load. If it is attached too close to the end of the load, it may not function correctly, and its capability to restrain cargo will be reduced or eliminated.

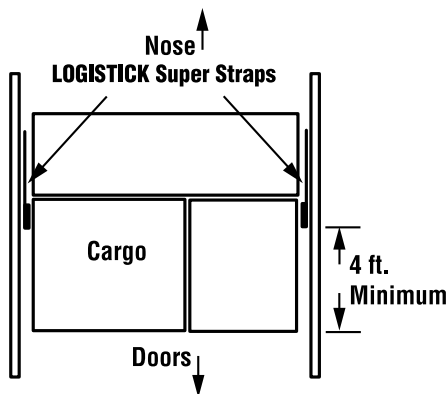

Strap Placement

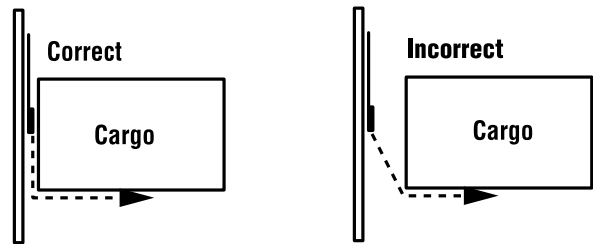

The handles must face away from the load. Placing the Super Strap a minimum distance of 4 ft. before the load ends ensures that any load shifting against the banding will not pull the Super Strap away from the wall. Any force against the Super Strap must be parallel with the trailer wall – not at an angle. Angular force reduces the adhesion power and increases the possibility that the Super Strap handles will pull away from the wall.

- 2 Important: Preparing the Surface.** The wall space where the Super Strap is to be located must be clean and dry. Wipe all loose dirt and dust from the application area with a dry cloth.

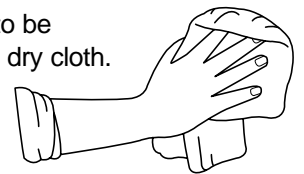

- 3 Applying the Banding.** Before applying the Super Strap to the desired area, attach flexible banding and buckles to each of the two Super Strap handles. The Super Strap is designed for use with plastic, nylon or steel banding, which is also available from Logistick. The use of hooks, rope or any material that does not allow the entire Super Strap to adhere to the wall is discouraged, because it may reduce the restraining capabilities.

When measuring banding length, be sure to include the distance from Super Strap placement to the load end, plus the width of the trailer.

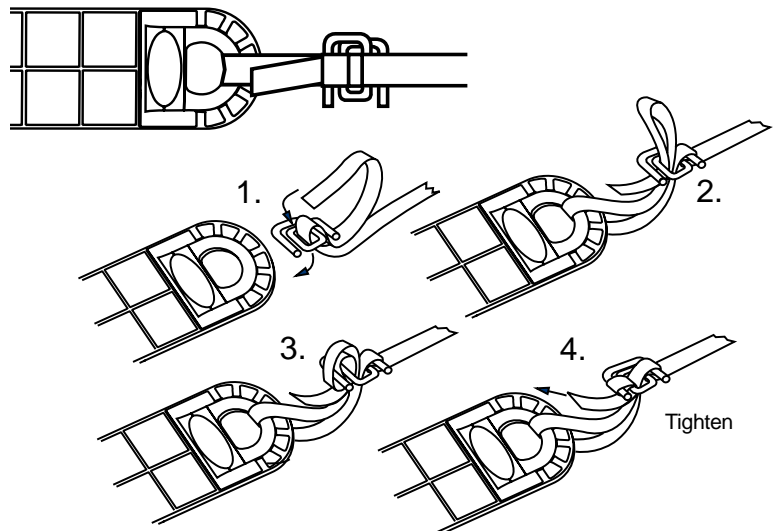

4 Applying the Super Strap to the Wall. Remove the adhesive cover, position on the wall and apply pressure using both hands. Repeat the procedure on the opposite trailer wall, making sure the Super Strap is at the same height and equal distance from the end of the load as the first strap.

Note: the handles of the Super Straps should always be pointing toward the end of the load.

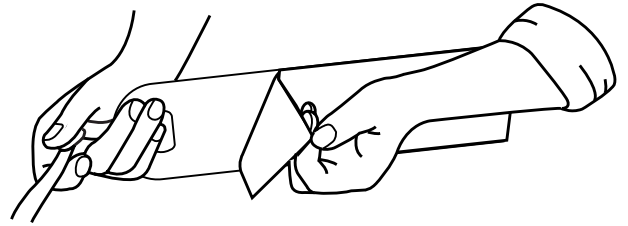

IMPORTANT: Once the Super Strap is in place, it should not be moved. Moving the Super Strap in any way will weaken or break the adhesive's initial bond and will not allow optimal performance.

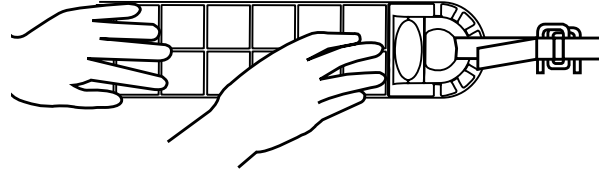

5 Using tape, temporarily secure the loose banding so it is out of the way while the remaining cargo is loaded.

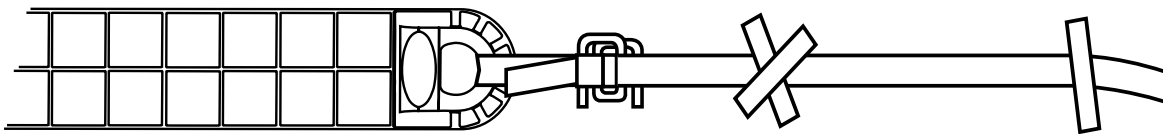

6 Securing the Freight Load with Band Buckles. When the freight loading is completed, wrap the flexible banding around the load end and secure the two ends together in the center of the load.

When the freight loading is completed, wrap the flexible banding around the load end and secure the two ends together in the center of the load.

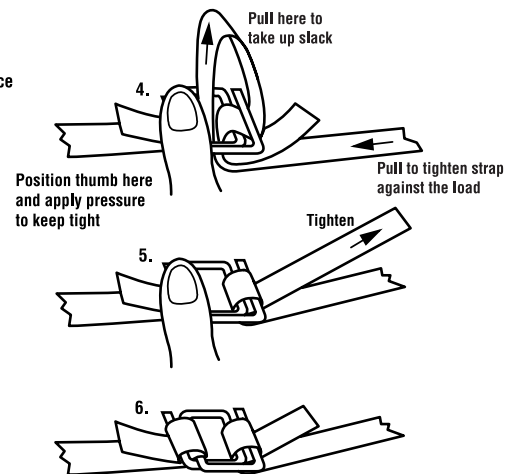
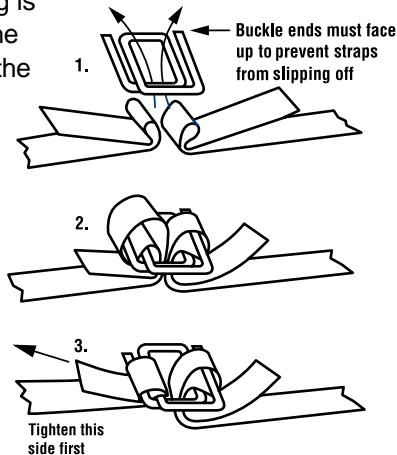
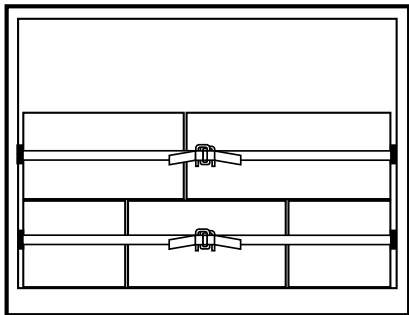

7 Strap Removal. To remove the Super Strap, simply cut the banding and, using the handle, pull the Super Strap down and to the rear. It should peel completely off the wall.

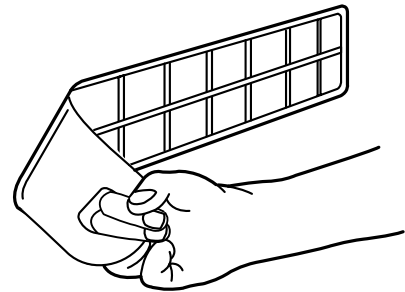

Innovators of Freight Securement Systems™

www.logistick.com

19880 State Line Road • South Bend, IN 46637-1545

1.800.758.5840 • 574.271.2565 • FAX 574.271.2574

WARNING: This product is not to be used in connection with the transportation of any "hazardous materials" as defined at 49 CFR § 171.8.

Logistick®, Inc. is a registered trademark. The Super Strap™ is a trademark of Logistick Inc.

LOGISTICK, INC. warrants its product to be free from any defects in material and workmanship. LOGISTICK'S obligation is limited to furnishing, on an exchange basis, replacement parts which may have been found defective upon LOGISTICK inspection. LOGISTICK assumes no shipping responsibility for replacement parts. EXCEPT AS SPECIFICALLY PROVIDED HEREIN, THERE ARE NO OTHER WARRANTIES, EXPRESSED OR IMPLIED, INCLUDING, BUT NOT LIMITED TO, ANY IMPLIED WARRANTY OF MERCHANTABILITY OR FITNESS FOR A PARTICULAR PURPOSE. In addition, under no circumstance will LOGISTICK, INC. be held liable for any damages or claims, including the losses of profit or business interruption, all of which are hereby expressly waived by the purchaser.