



Innovators of Freight Securement Systems[®]

Intermodal Strap[®]

The one-way solution for securing light to medium weight, regular or irregular shaped loads in intermodal shipping containers.

Installation Guide

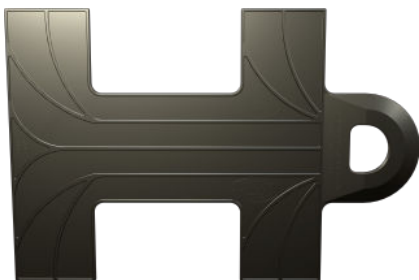

The complete Installation Guide for Logistick's Intermodal Strap[®].

For best results, please read through all instructions prior to installation.

Materials Needed

- Intermodal Strap[®]
- AAR Buckles
- AAR Banding
- Dry Cloth
- Tape
- Banding Tensioner (optional)
- Scraper (optional)
- Rubbing alcohol (optional)
- Corner Protectors (optional)

1. Choosing the Application Area

Before or while loading the freight, determine the best location for installation. Keep in mind that multiple sets of Intermodal Strap[®] may be needed to safely secure your freight. The Intermodal Strap[®] is designed to adhere to the peaks of the container wall and should be placed an equal distance from the floor and **6 feet, or about 2 pallet rows, BEFORE the end of the load**. The wall void between the freight and the container wall needs to be 3 inches or less. This placement is critical because it helps maximize the shear strength of the Intermodal Strap[®].

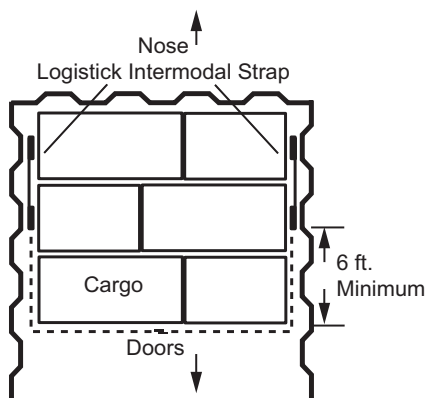

Strap Placement

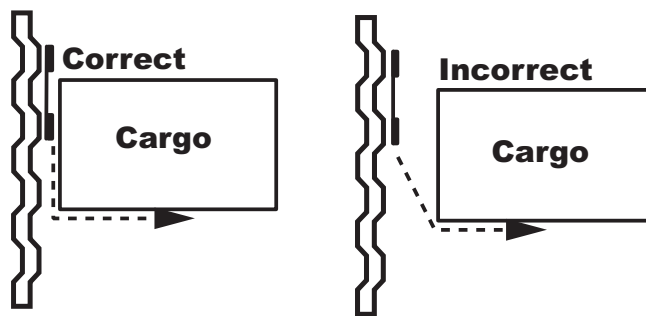

2. Prepping the Application Area

The entire application area must be clean and dry to ensure proper installation. Use a dry cloth, and if needed, a scraper and rubbing alcohol to remove loose dirt, dust, condensation or frost from the application area.

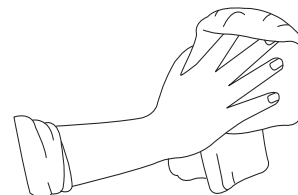

3. Adhering Intermodal Strap®

The Intermodal Strap® needs to be positioned so the entire adhesive surface on both wings will make direct contact with the container wall. The handles, which are the anchor points, must be directed **towards the end of the load or in the direction the freight could move.**

To install the first Intermodal Strap®, remove the backing from both wings and place the Intermodal Strap® on the wall and **at least 6 feet before the end of the load.**

Press firmly against the wings of the Intermodal Strap® to assure that the tape bonds to the wall. Repeat this procedure with the second Intermodal Strap® on the opposite wall, making sure that it's adhered at the same height.



IMPORTANT: Once Intermodal Strap® is installed, it cannot be repositioned.

4. Attaching AAR Banding to Intermodal Strap®

Two pieces of appropriately rated AAR banding and three AAR buckles are recommended with the Intermodal Strap® system. To determine the proper cut length for each piece of banding, be sure to include the distance from the Intermodal Strap® to the end of the load, plus the full width of the container. Next, attach the AAR banding to each Intermodal Strap® handle using a buckle.

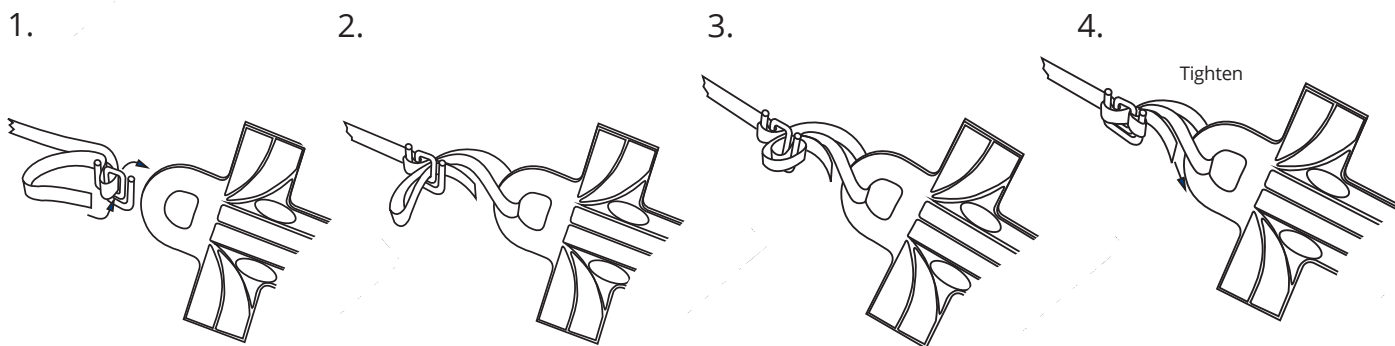

5. Temporarily Secure Banding

Using tape, temporarily secure the two pieces of loose banding to the container wall so they will be out of the way and accessible after the freight is loaded.



6. Securing the Freight

Once the remaining freight has been loaded, pull the two pieces of loose banding around the end of the load and use a buckle to fasten the pieces of banding together in the center of the load. Corner protectors may be needed to prevent the banding from damaging the packaging. After buckled, pull tight and then use a banding tensioner to secure the freight.

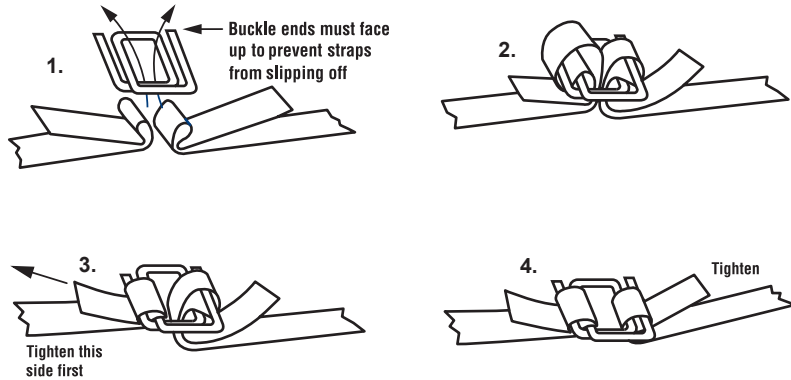

If you have any questions about this product or any of our other products please email us at sales@logistick.com

Thank you for your business and continued partnership.

Logistick.com



Scan for full video!



Innovators of Freight Securement Systems®



Innovators of Freight Securement Systems®

Intermodal Strap®

The one-way solution for securing light to medium weight, regular or irregular shaped loads in intermodal shipping containers.

Removal Guide

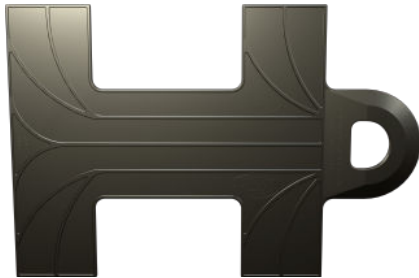

The complete Removal Guide for Logistick's Intermodal Strap®.

Materials Needed

- Safety Knife or Scissors
- Prybar
- Cloth (optional)
- Scraper (optional)
- Citrus Based Adhesive Remover (optional)

1. Removal of Intermodal Strap®

Unsecure the load by cutting the banding and then unload the freight. Remove each Intermodal Strap® from the container wall by inserting a prybar down between each wing and the wall. Pry and pull downward and away from the wall until the Intermodal Strap® is removed.



2. Removing Tape Remnants

Use a cloth, and if needed, a scraper and a citrus based adhesive remover to clean any remaining tape residue from the container walls.



Scan for full video!



Innovators of Freight Securement Systems®

Revised October 2022
L.21